

8 7 6 5 4 3 2 1

F
E
D
C
B
A

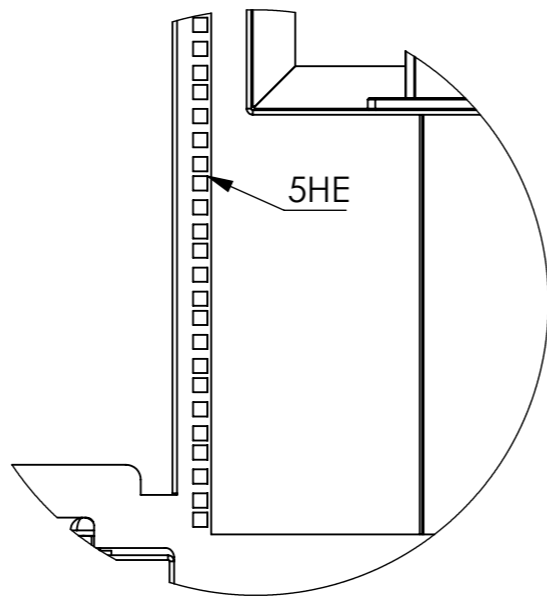

C (1 : 5)

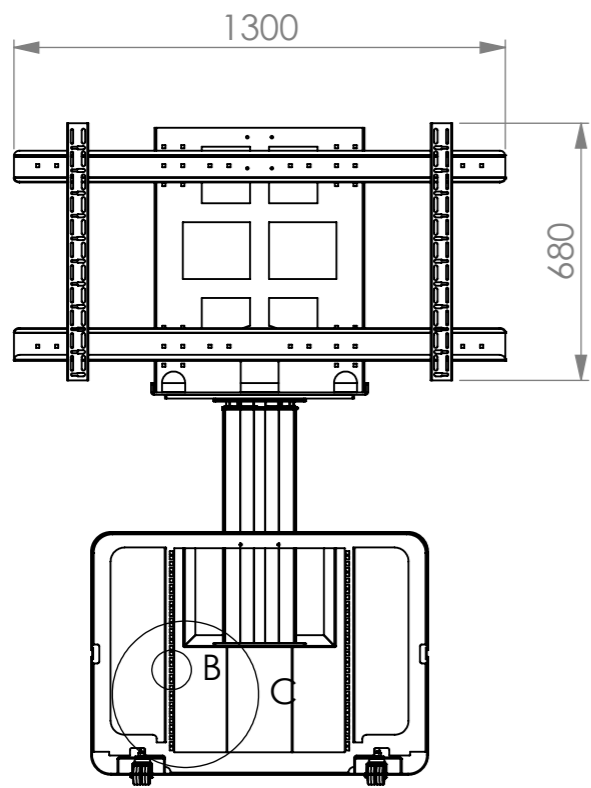
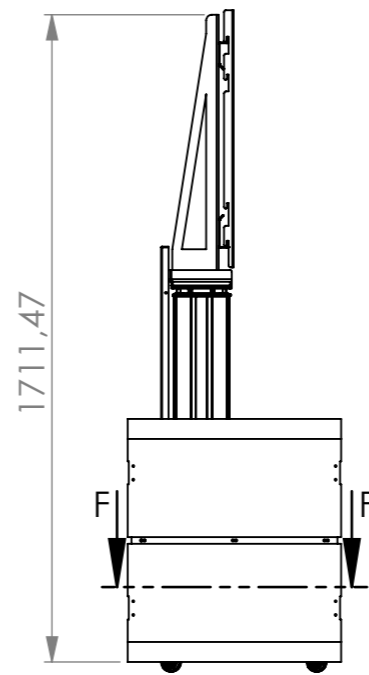

375 Maximale Einbautiefe

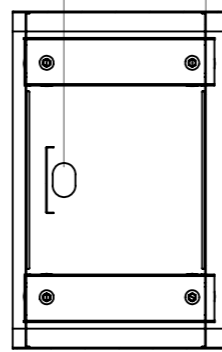

F-F

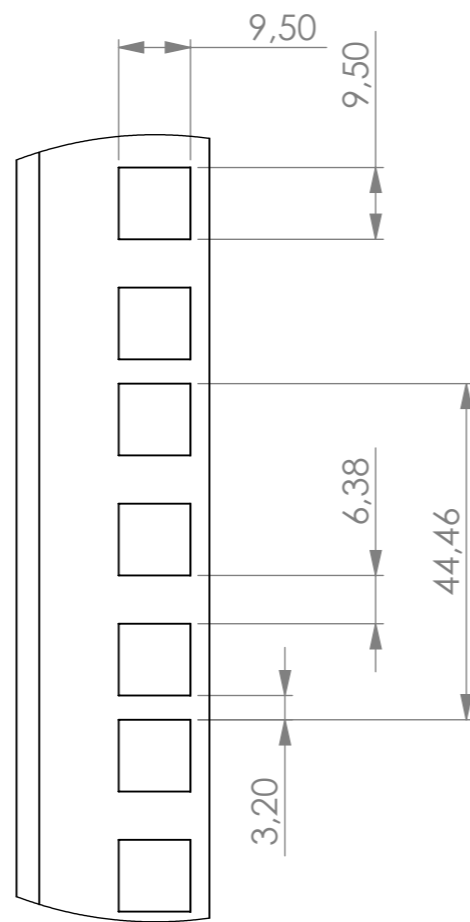
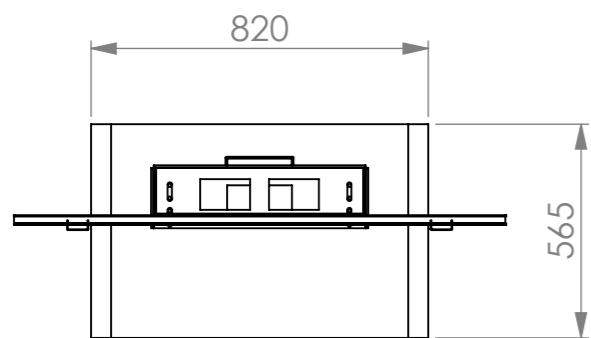
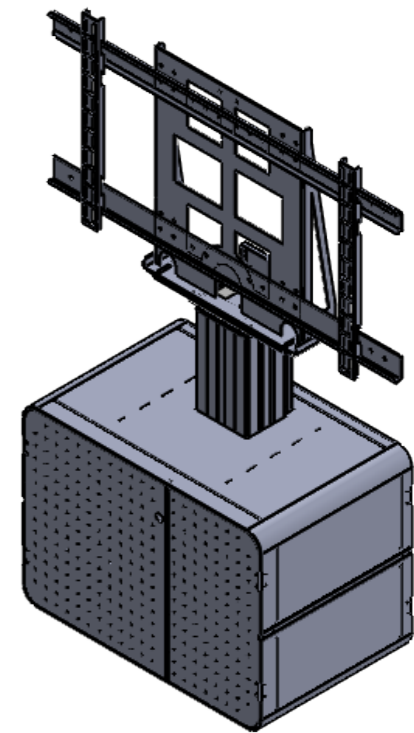

B (1 : 1)

WENN NICHT ANDERS DEFINIERT: BEMASSUNGEN SIND IN MILLIMETER OBERFLÄCHENBESCHAFFENHEIT: TOLERANZEN: LINEAR: WINKEL:	Zul. Abw.		Farbe:		Gewicht:	MASSSTAB:1:20	
					WERKSTOFF:		
					Artikel:		
					E-Space Hub Artikelnummer: 100913.1		
				www.peta-gmbh.de		BLATT 1 VON 1	

8 7 6 5 4 3 2 1